

Installing a Steel Moment Frame

by Patricia Hamilton

New custom-designed oceanfront homes all seem to share one feature: lots of glass looking out on the water. In the case of one house we recently built, the architect filled most of the east side of the house with an expansive two-story window-wall (see Figure 1), so no effective plywood shear walls could be incorporated (see “Strength of Plywood Sheathing,” *Practical Engineering*, 11/96). To achieve lateral stability on that side of the house, we integrated a structural steel moment frame into the wood framing.

A Moment for Definitions

The word “moment” is a physics term adopted by engineers to refer to “the measure of a force with reference to its effect in producing rotation.” (This is the same thing your auto mechanic calls torque.) A moment is a

product of a force and a distance, and is typically measured in foot-pounds. As the distance gets greater, the moment gets larger. That’s why you use a long ratchet handle to unscrew a tight bolt: The force of your arm is multiplied by a greater distance, increasing the moment you’re applying to the bolt. But what’s this got to do with a wall?

Wood-framed residential structures typically rely on plywood sheathing to resist lateral wind loads. As every builder knows, when you stand up a framed wall with no sheathing on it, it takes practically no force at all to rack that wall. But once you nail on the sheathing, the wall is rock-solid against racking.

When a lateral force is applied at the top plate of an *unsheathed* wall and the wall racks, the studs rotate with respect to the top plate (Figure 2). A plywood-sheathed wall, acting as a shear wall, removes the rotational force. Instead, the plywood, stiffened by the wall

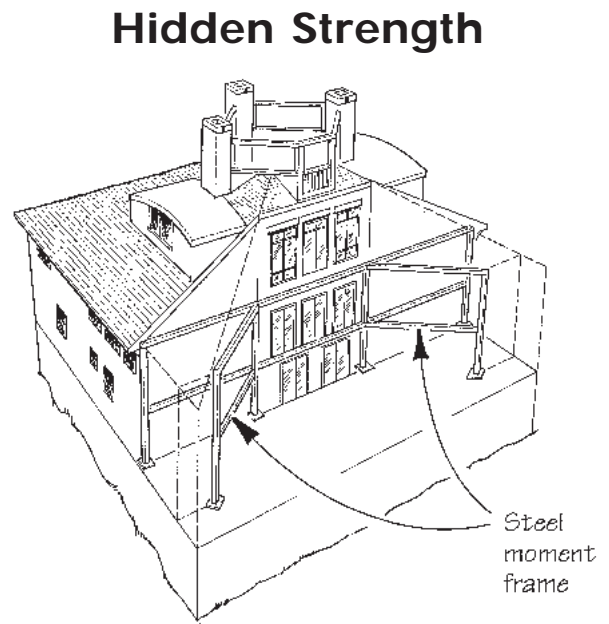

Figure 1. The expanse of windows walls in the east wall of this oceanfront home leaves no room for plywood shear walls (left). A structural steel moment frame embedded in the framing (right) handles large lateral wind loads.

Resisting Rotation

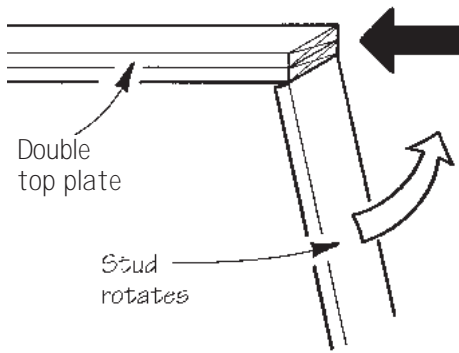

Figure 2. When a stud wall racks, the studs rotate with respect to the plates. A moment connection resists this type of rotation.

studs, safely transfers the lateral force to the foundation.

Plywood shear wall sections generally need to be at least 4 feet long to be effective. But what do you do with a wall that's so broken up with doors and windows that there's no room for plywood? It's difficult to achieve a rigid structure with unsheathed wood framing alone. Even if you use steel connectors and heavy timbers or builtup posts and beams, the wood itself still has a tendency to crush and split, allowing rotation at the joints. (One exception is a timber frame with knee braces.)

Steel to the Rescue

Steel moment frames are typically used in low- to mid-rise steel-framed commercial buildings, and can be adapted for residential construction. A moment frame consists of at least two columns and one beam. The welded connections where the beams join the columns have the full strength of continuous steel, so they can resist rotational forces. These moment connections work together with the stiffness of the steel members to prevent the frame from racking.

The moment frame for this house had six columns and ten beams, and supported the top two floors on the east face of the 55-foot-wide house. The complexity of the steel frame was typical of the oceanfront homes we

build, but the techniques we used and problems we encountered would apply to simple projects as well.

A steel moment frame, as you might imagine, is considerably more complicated than using a single steel beam in a garage. The posts and beams all have to be carefully sized, connection and reinforcing plates welded on, and the steel punched in various places for bolting on wood members.

Although we erected the steel ourselves, we had an experienced local shop fabricate the necessary components. The fabricator worked with the architect's and the engineer's drawings to create a set of shop drawings. These showed the size and layout of each of the parts, as well as all the necessary bolt holes. We carefully reviewed the drawings, comparing all three sets to make sure that nothing was overlooked. After our final okay of the drawings, fabrication began.

Meanwhile, we framed the first-floor deck and lined up a crane for the big day. When the steel arrived, we first unloaded the individual pieces and sorted them on the plywood deck. The fabricator sent along a set of erection drawings. Each piece of steel was numbered and each end labeled so that matching the parts to each other was simple.

The primary section of frame was a line of four columns supporting two tiers of three beams each, one tier at the second-floor level and one at the third-floor level. We assembled these as two separate sections, with connecting beams to go between them once they were stood up (Figure 3). We bolted these sections together, hand tight, while they lay on the deck. Then, using the crane, we stood up each section and lag-screwed the column baseplates to solid blocking in the floor (or in some cases, to the tops of pilings), using four 1/2-inch lag screws per base, per the engineer's specs. Next, we braced the columns using long 2x4s fastened to the steel with big C-clamps. Once these two sections were up, we set the connecting beams between them. Finally, we set the two outlying columns and beams that came off the main frame at an angle.



Figure 3. The author erected the moment frame in two main sections, then dropped connecting beams into place.

Because the frame stood two stories tall, it was a little tricky to plumb. We used our 8-foot level to plumb and brace the bottom 10 feet of the frame. We then welded the moment connections at the first-floor level, and built the first-floor walls around the frame. We next built the second-floor platform, checked the upper sections of the moment frame for plumb, and welded the upper connections.

Attaching Wood

The final headache was to actually integrate the steel into the wood-framed walls and floors of the house. As much as possible, we had the steel prepunched so we could simply bolt 2-bys all around (Figure 4). Columns in walls received nailers on both sides. The exterior sheathing and the interior drywall then bridged the column from nailer to nailer. We attached nailers to the top and bottom flanges of I-beams and filled the webs with blocking. Some of the columns were square tubes, which can't be prepunched. Instead of drilling the tubes, we attached the wood framing with powder-actuated fasteners. This was expensive and noisy, but quite effective.

The importance of these wood-to-steel attachments should not be underestimated. The proper transfer of lateral forces from the floor and roof diaphragms to the steel moment frame depends on their connection to the

steel members. If these connections are weak, the moment frame can't effectively brace the entire structure. ■

Patricia Hamilton owns Boardwalk Builders in Rehobeth Beach, Del. Thanks to Paynter Ingram, P.E., of Gredell & Associates, in Dover, Del., for his assistance with this article.

Curious about the forces that hold a building together — or cause it to fall apart? Address your questions to Practical Engineering, JLC, RR 2, Box 146, Richmond, VT 05477.



Figure 4. Steel I-beams can be prepunched for bolts; with tube steel, it's easiest to fasten lumber with powder-actuated fasteners.