

LETTERS

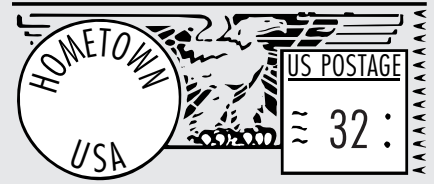

Simpler Water Level

To the Editor:

Regarding the article "Water Level Know-How" (*Toolbox*, 8/95): A third method of water-leveling is the two-person "very simple system" in which you make a mark on the wall at an appropriate level, give one end of the hose to a helper, go to wherever it is you want to level (with a thumb over the end of the hose), then raise or lower the end of the hose until your helper sings out "Yo! It's on the line!" You wait a few seconds to make sure the water has stopped moving, and mark it. Then you're off to the next location. Who cares if you spill a little water, because you automatically recheck it each time your helper hollers out "Yo!"

The smaller the hose, the more the margin of error, because the meniscus seems to have some sort of friction. I use a $3/8$ -inch clear hose with no problem.

Gerret Wikoff, G.C.
Los Angeles, Calif.

Baluster Testing Questioned

To the Editor:

Your testing of balusters ("Are Balusters Strong Enough?" *Practical Engineering*, 6/95) does not hold much weight in following code rules. BOCA section 1615.8.2.1 requires that balusters be designed and constructed for a horizontal concentrated load of 200 pounds over a one-square-foot area at any point in the system.

The lab testers did not do this. They applied a vertical load to a single baluster. A system means repetitive balusters attached at top and bottom to a handrail, floor, ceiling, stairs; not lying freely on a workbench. The handrail, for example, carries part of the horizontal force to the adjacent balusters.

The authors also erred on the 4-inch space between turned interior balus-

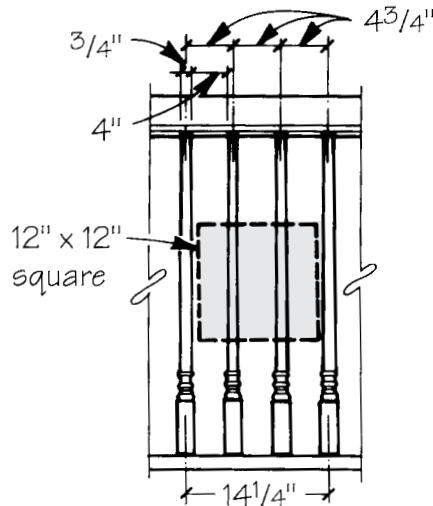

ters, wrongly calculating that only two balusters will make contact with one square foot of force. The 4-inch space is designed to keep a child's head out, hence a turned baluster will have to be moved closer than 4 inches at the fat end so the tapered end meets the minimum 4-inch requirement. Thus, three balusters will meet the one-square-foot force using the supposedly "inferior" turned balusters.

Chris Gabiou
Osburn, Idaho

Robert and Christopher Randall respond:

The application of a vertical load to a horizontal baluster was a practical way to use gravity to apply a load perpendicular to the baluster. Looking closely at the photo, you can see that the ends of the baluster were set into holes in wooden blocks, simulating normal installation in a railing assembly. Your point about the handrail carrying loads to other parts of the system is true, but that doesn't lessen the load that the individual baluster must carry.

A basic principle of engineering is that analysis of a structure should be based on the most critical conditions foreseeable. The location we chose for the application of the load was the most critical one for the balusters.

If the balusters were tapered, the spacing might have been closer, as suggested.

But even if the tapered portions were only $3/4$ inch in diameter, the required center-to-center spacing would be $4 3/4$ inches maximum, resulting in $14 1/4$ inches between centers of first and fourth balusters. Conservative analysis would still require the selection of the most critical location for load application, which would only involve the two center balusters (see illustration at left).

By moving the designated square to the right or the left, we could involve three balusters, but that would not be conservative and would violate good engineering practice. In actual practice, balusters are often spaced even farther apart.

You could also have asked why we chose a one-foot square rather than perhaps a circle or a rectangle of one-square-foot equivalent area. This was perhaps the most arbitrary aspect of the loading assumptions we used.

Mr. Gabiou's letter reinforces our contention that this code requirement needs clarification.

Redwood, Cedar Decks More Stable

To the Editor:

On the House recently featured a question titled "Twisted Deck Boards" (7/95). The real problem is that treated wood is made from pine or similar species that are not dimensionally stable but are inexpensive for the treating company. The solution is to use a stable species like redwood or the more plentiful western red cedar.

Robert W. Thompson
MacMillan Bloedel Ltd.
Vancouver, B.C.

Keep 'em coming! Letters must be signed and include the writer's address. The *Journal of Light Construction* reserves the right to edit for grammar, length, and clarity. Mail letters to JLC, RR 2, Box 146, Richmond, VT 05477; or e-mail to