

COMMON ROOF-FRAMING ERRORS

Problems and solutions for trusses, rafters, collar ties, and structural ridges

As a builder turned lumber industry representative, I've seen a lot of roof framing — some good, some not so good. It seems that houses have become larger and their roof systems more complicated. In light of this, it's worth revisiting the most common framing errors I see on both conventional and truss-framed roofs.

Toe-Bearing Rafters

A common error with low-slope rafters is excessive cutting of the rafter seat. This leaves the rafter bearing not on the heel of the seat cut, as it should, but on the toe (see Figure 1). The seat cut may run straight from toe to heel, or there may be a deep birdsmouth at the inside edge of the wall — from a structural standpoint there's no difference.

There are two problems with this. One is that you no longer have the full width of the rafter to carry the load. Bearing on the toe effectively reduces the width of the entire rafter. The other problem is that the shear created by the flexing of the rafter can cause a split to start at the inside edge of the top plate. This is a particular problem with cathedral ceilings, where split rafters can lead to cracks in the ceiling drywall. The lumber's slope of grain will determine how likely it is to split, if at all.

But what if your roof is framed with 2x10s when, structurally, you only require 2x6s? Can't you safely overnotch the 2x10 to create an effective 2x6? The answer is no. For one thing, you still risk splitting the rafter. For another, lumber is graded to allow certain types of defects in certain parts of the

by David Utterback



Figure 1. The rafters in the photos above are incorrectly bearing on the toe rather than the heel — risking a split in the rafter. A level cut (top) and a birdsmouth (above) are structurally the same in this respect. The wire holes in the bottom photo only make the rafters more likely to split.

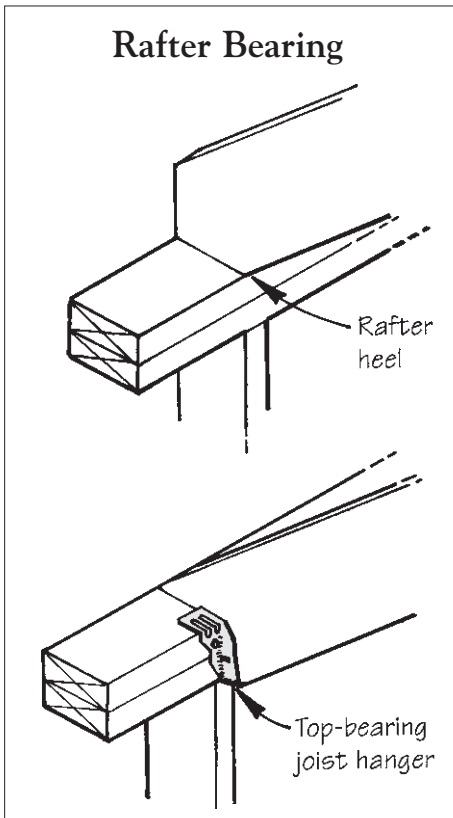

Figure 2. It's best to rest the rafter heel on the plate (top). Where this isn't possible, you can sometimes support it with a joist hanger (above). The joist hanger also keeps the rafter from rotating, a job that normally requires ceiling joists or solid blocking.



Figure 3. The rafters in this house have been stiffened with a purlin that runs the length of the roof. Because the struts that hold the purlin bear on a set of unsupported ceiling joists, however, chances are that the ceiling will eventually crack. To properly support the roof, the braces need to go from the purlin to a bearing wall.

lumber's cross-section. For instance, larger knots are allowed in 2x10s than in 2x6s. Turning a 2x10 into a 2x6 may put large knots close to the edge, ruining the board's structural integrity.

You can avoid all these problems by cutting the rafter so that it bears on the heel of the seat cut, rather than the toe. If that's not possible, try putting a ledger strip beneath the rafters to catch the heel, or support the rafters with joist hangers nailed into the top plates (Figure 2).

Transferred Loads

Another big problem with roof systems in today's large houses is load transfer. The complexity of some roof structures makes it hard to properly support some of the members. I see too many hips and valleys that are totally unsupported; sometimes these hips and valleys tie into lower ridges that are also unsupported.

Hip and valley rafters need to land on headers or doubled-up rafters sized to handle the loads. Headers around openings like skylights don't necessarily need to be plumb. But remember that the loads on a roof are vertical — not perpendicular to the rafters — and that lumber is strongest when placed on its edge. This means that, in most situations, the header should be put in plumb and its members stepped to follow the roof slope. A rule of thumb is that headers up to 4 feet long can be put

in square with the rafters, while anything over 4 feet should be plumb. Header rafters more than 6 feet long should be supported by framing anchors.

Roof loads are also transferred by the purlins and struts used to break up rafter spans. Where I live, near Kansas City, every house has these — even inexpensive starter homes. Too often, the struts are not properly located. Diagonal struts must extend to bearing walls at less than a 45-degree angle from the horizontal. If the struts land on strongbacks set across undersized ceiling joists (Figure 3) or fall on non-bearing walls, the ceiling finish may crack or the doors in those nonbearing walls may bind and stick.

No Rafter Ties

Cathedral ceilings present special problems. If there are no ceiling joists, you must find another way to keep the rafters from pushing the exterior walls out. If not, symptoms can develop up to a year or two after the house has been built, and include cracks at the wall-ceiling intersection, cracks above headers, and walls that are greatly out of plumb. No builder needs callbacks on problems like these.

In rooms with attics above them, the ceiling joists or the bottom chords of the trusses create a tension tie between the outside walls. In a cathedral ceiling, open rafter ties can serve the same pur-

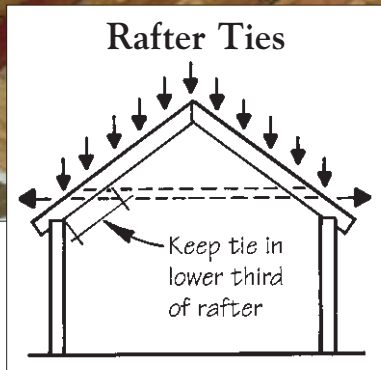
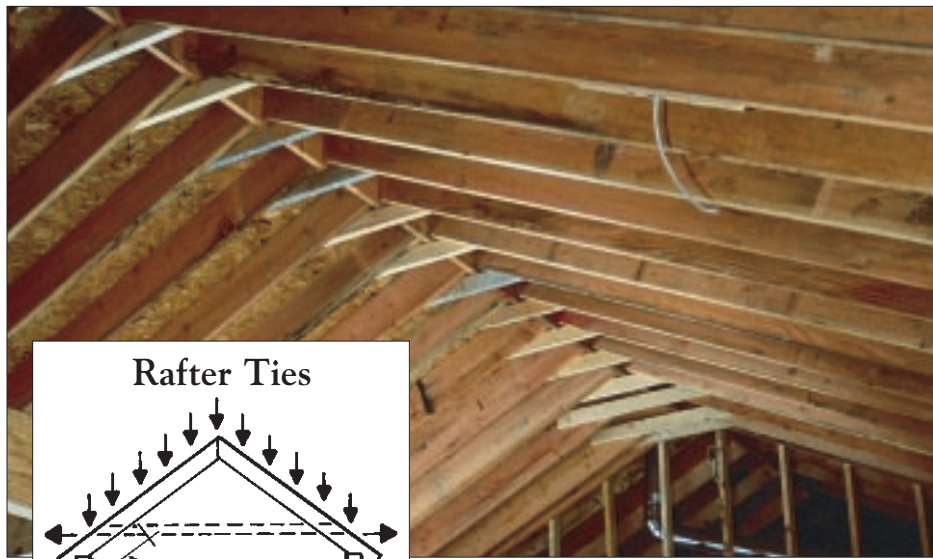

Figure 4. As rafters settle, their outward thrust pushes out on exterior walls. Rafter ties should be placed in the lower third of the rafter span so they have enough leverage to resist this thrust. The ties in this photo serve no structural purpose.

pose if they're not placed too high. A good rule of thumb is that unless the roof structure has been specially engineered, don't place the rafter ties above the lower third of the rafter span (Figure 4); otherwise, they won't have enough leverage to resist the rafters' outward thrust.

You'll understand this if you think about the way a tree pruner works. Grabbing the handles at the end gives you plenty of leverage to cut off the limb; grabbing them near the cutter head makes the job considerably harder. Rafter ties do the same thing in reverse — instead of trying to squeeze the outside ends of the rafters together, the rafter ties keep them from moving farther apart. The closer the ties to the bottom of the rafter, the greater the leverage.

If you install ceiling joists near the center of a rafter span and hang drywall from them, you increase the dead load on the roof at the rafter's maximum bending point. This will cause the rafter to deflect and push out on the outside walls even more (Figure 5).

Ridge beams. You can also prevent cathedral ceiling rafters from pushing the walls out by using a structural ridge beam. By holding up the top of the rafters, a structural ridge lets the exterior walls carry the vertical loads applied to them by the rafters, but reduces the outward thrust. Keep in mind that a beam has to be sized to carry the load

that will be imposed on it, and that the beam will have a limited span capability. It will also need proper supports at each end, and, if necessary, along its length. Too often I see ridges that are neither properly sized nor properly supported. Many times the only thing holding up the ridge beam is the rafters themselves, which obviously defeats the purpose of the ridge beam. Designing a structural ridge is a bit complicated for the average builder, so get an engineer to do the calculations.

There are two ways to join rafters to a structural ridge: You can either butt the plumb cut to the ridge beam or you can cut a birdsmouth in the rafters and set them on top of the ridge. Either way is acceptable, as long as you follow the guidelines in Figure 6. A toe-nailed connection is not strong enough.

Trusses

As one would expect from engineered components, trusses present a different set of problems than solid lumber.

Field alteration. Don't try this on your own. Since trusses are engineered systems, they shouldn't be altered on the job site. To do so destroys the integrity of the truss. If you absolutely have to cut a truss, call the truss engineer.

Improper bearing. The average truss is designed to bear on the outside walls of a building and to clear-span everything between. One of the most frequent framing errors I see is nailing the

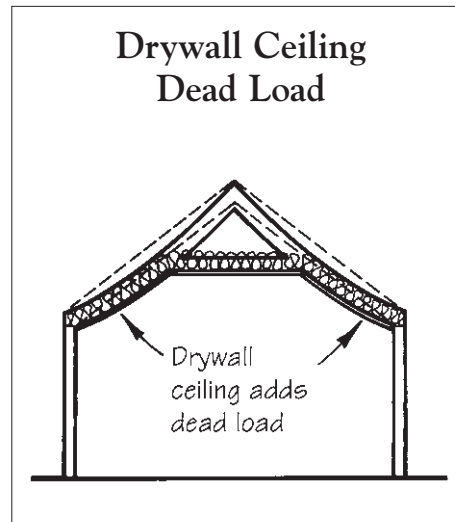

Figure 5. Hanging a ceiling near the middle of the rafter span adds dead load to the rafter at its maximum bending point. Avoid this detail, or use a structural ridge to reduce the outward thrust of the rafters and design the rafters to support the additional dead load.

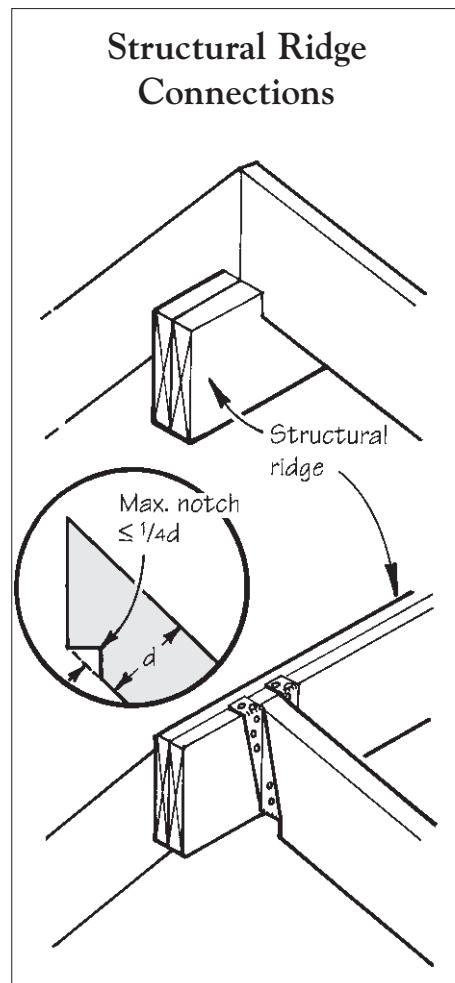

Figure 6. The most effective way to reduce outward roof thrust is to use a structural ridge beam. Either rest the rafters on top of a structural ridge (top) or use joist hangers attached to the ridge beam (above). The notch at the bottom of the plumb cut should be no deeper than one-fourth the rafter width.



Figure 7. Most roof trusses are designed to bear only at the exterior walls. Avoid nailing roof trusses to interior partitions (far left); otherwise, as the bottom chord rises with changes in moisture content, it will move the wall with it and open up cracks in the ceiling drywall. Instead, use truss clips (left), which allow the truss to move independently of the partition wall.

bottom chords of roof trusses to interior partitions. A truss can be engineered with an additional bearing point along its bottom chord, but on the typical roof truss, creating an additional bearing point on the bottom chord will redistribute the loads through the truss. This can cause web members designed for tension to become compression members and vice versa. In extreme cases, the truss could fail.

Another problem with nailing to interior partitions is cracked drywall from truss movement. During the winter months, the uninsulated top chord picks up moisture from the air and expands. As it expands it arches,

pulling the bottom chord up with it. If the bottom chord is nailed to an interior partition, either the nails will simply pull loose or the rising truss will pull the wall right off the floor, opening a gap below the baseboard. Most of the calls I get about this are complaints from builders that the floor joists are shrinking. But once I tell them to measure the joists and check them for level, they find out that while the joists may contribute to the problem, something else is going on.

What can be done about rising trusses? First of all, don't shim under the wall. The trusses and the wall will nearly always come back down in the summer.

If you try to prevent this from happening, you'll create that unwanted bearing point I mentioned earlier. You can also replace the nails holding the bottom chord to the wall with truss clips — metal connectors that let a truss move up and down without taking the wall with it (Figure 7). If you use truss clips, don't screw the ceiling drywall to the truss where it passes over the partition. Instead, hold your screws 12 to 14 inches back from the partition and screw the edge of the ceiling to 2-by nailers that have been fastened to the top plate between the trusses. This will let the drywall flex and prevent a crack from forming at the wall/ceiling intersection.

Inadequate bracing. Lack of bracing is one of the biggest causes of failures in truss roofs. Builders who use trusses should be aware that there are standard bracing procedures that should be followed on all jobs. These include diagonal bracing at the ends of the building and lateral bracing of the top and bottom chords (the sheathing usually serves as bracing for the top chord). Lateral bracing keeps the trusses from flexing and diagonal bracing prevents strong winds from toppling the trusses in a domino effect (Figure 8). Bracing of web members is usually left to the engineering design. These and any other special bracing requirements will be detailed on the spec sheet that should go out with every truss job. ■

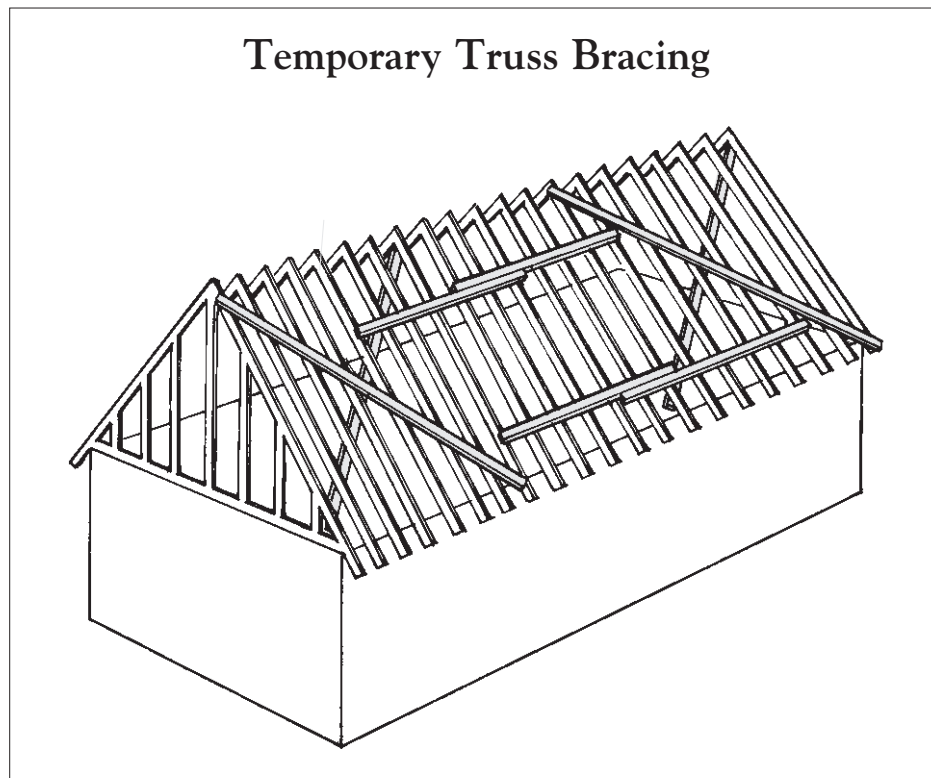

Figure 8. To prevent a domino collapse while setting a truss roof, install temporary diagonal bracing at each end of the building and horizontal braces every 25 feet along its length.

David Utterback is a district manager for Western Wood Products Association and WWPA's designated code expert. Before joining WWPA, he was a contractor specializing in residential and commercial wood-frame construction.